

*Facoltà di Ingegneria Civile e Industriale  
Ambiente e Territorio, Sicurezza*

# Scienza delle Costruzioni

Paolo Casini

Dipartimento di Ingegneria Strutturale e Geotecnica  
Università di Roma *La Sapienza*

E-mail: [p.casini@uniroma1.it](mailto:p.casini@uniroma1.it)  
pagina web: [www.pcasini.it/disg/sdc](http://www.pcasini.it/disg/sdc)

**Testo di riferimento:**  
Paolo Casini, Marcello Vasta. *Scienza delle Costruzioni*,  
CittàStudi DeAgostini, 4° Edizione, 2020



**SAPIENZA**  
UNIVERSITÀ DI ROMA



# Lezione

## Parte IV - Il Problema di Saint Venant

- Obiettivi, Generalità
- 1. Forza normale centrata
- **2. Flessione retta (flessione uniforme retta)**
- 3a. Flessione deviata (flessione uniforme deviata)
- 3b. Tensoflessione
- 3c. Forza normale eccentrica
- 4. Flessione e taglio (flessione non uniforme)
- 5. Torsione uniforme



## 2. Flessione retta (flessione uniforme) $M_x$ (o $M_y$ )

- **Posizione del problema**
- **Ipotesi sulla soluzione (tensioni)**
- **Formulazione analitica e soluzione**
- **Flessione retta  $M_y$**
- **Esercizi (sito: E16, testo: §18.4-18.6)**

## 2. Flessione retta $M_x$

### Posizione del problema

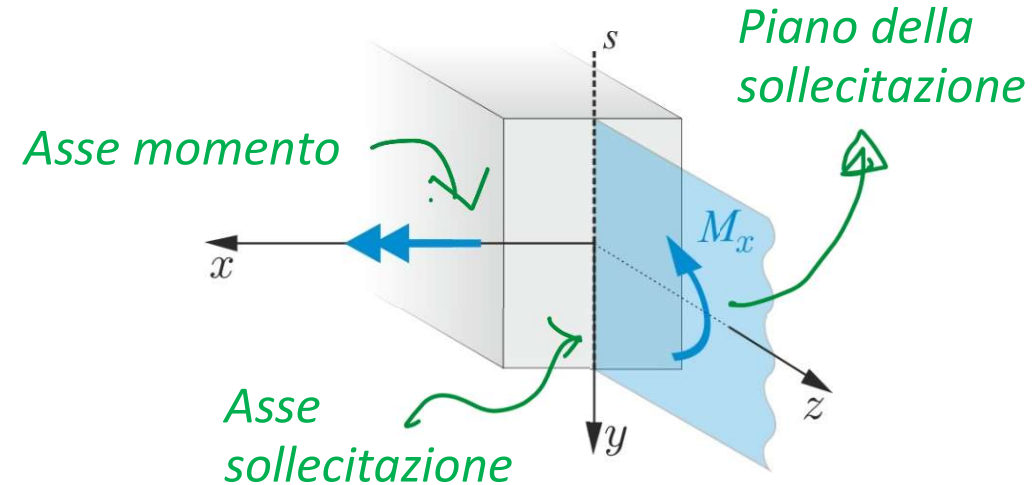
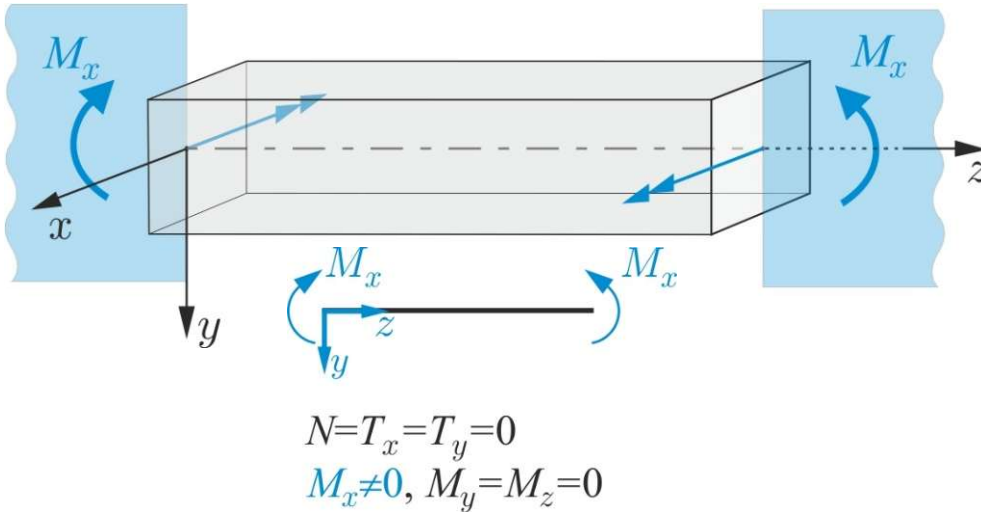

### Ipotesi sulla soluzione (tensioni)

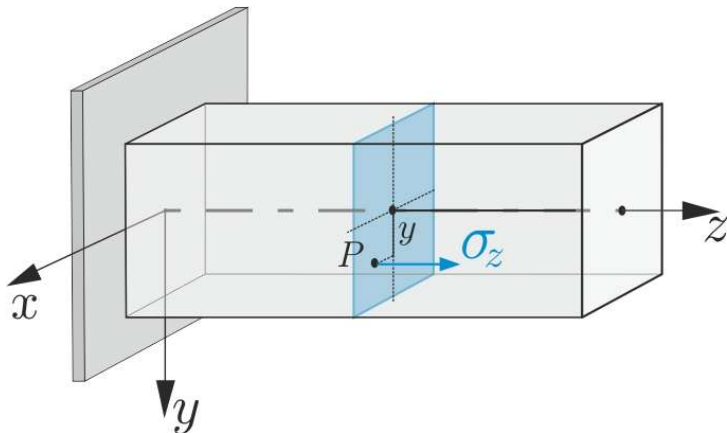

$$\sigma_z(P) = ky$$

$$\tau_{zy}(P) = \tau_{zx}(P) = 0$$



$$T(P) = \begin{bmatrix} 0 & 0 & 0 \\ 0 & 0 & 0 \\ 0 & 0 & ky \end{bmatrix}$$

$$\boldsymbol{\tau} = \mathbf{0}$$



### INCOGNITE:

*Forma compatta*

**Incognite cinematiche**

$$\mathbf{u}(P), \mathbf{E}(P)$$

**Incognite statiche**

$$\mathbf{T}(P)$$

*Forma scalare*

*(sistema di riferimento locale)*

**Incognite cinematiche**

$$u(P), v(P), w(P)$$

$$\varepsilon_x(P), \varepsilon_y(P), \varepsilon_z(P)$$

$$\gamma_{zy}(P), \gamma_{zx}(P)$$

**Incognite statiche**

$$\sigma_z(y) = ky$$

$$\tau_{zy}(P) = 0, \tau_{zx}(P) = 0$$

# 1. Problema SV: formulazione analitica

## Equazioni implicite di congruenza

$$\varepsilon_x = \frac{\partial u}{\partial x}, \varepsilon_y = \frac{\partial v}{\partial y}, \varepsilon_z = \frac{\partial w}{\partial z}, \quad \gamma_{xy} = \frac{\partial u}{\partial y} + \frac{\partial v}{\partial x}, \quad \gamma_{xz} = \frac{\partial u}{\partial z} + \frac{\partial w}{\partial x}, \quad \gamma_{yz} = \frac{\partial v}{\partial z} + \frac{\partial w}{\partial y} + c.c.$$

## Equazioni indefinite di equilibrio

$$\boldsymbol{\tau} = \tau_{zx}(x, y)\mathbf{i} + \tau_{zy}(x, y)\mathbf{j} = \mathbf{cost}_z$$

$$\operatorname{div} \boldsymbol{\tau} = -\frac{\partial \sigma_z}{\partial z}, P \in \mathcal{C}$$

$$\boldsymbol{\tau} \cdot \mathbf{n} = 0, P \in \Gamma$$

$$N = \int_{\mathcal{A}} \sigma_z dA \quad T_x = \int_{\mathcal{A}} \tau_{zx} dA \quad T_y = \int_{\mathcal{A}} \tau_{zy} dA \quad P \in \mathcal{A}$$

$$M_x = \int_{\mathcal{A}} \sigma_z y dA \quad M_y = -\int_{\mathcal{A}} \sigma_z x dA \quad M_t = \int_{\mathcal{A}} (\tau_{zy} x - \tau_{zx} y) dA$$

## Legge generalizzata di Hooke

$$\varepsilon_x = -\frac{\nu}{E} \sigma_z \quad \varepsilon_y = -\frac{\nu}{E} \sigma_z \quad \varepsilon_z = \frac{1}{E} \sigma_z \quad \gamma_{zx} = \frac{1}{G} \tau_{zx} \quad \gamma_{yz} = \frac{1}{G} \tau_{zy}$$



## 2. Flessione retta $M_x$

### Equazioni indefinite di equilibrio

$$\boldsymbol{\tau} = \text{cost}_z \quad \text{Verificato } \checkmark$$

$$\text{div } \boldsymbol{\tau} = -\frac{\partial \sigma_z}{\partial z} \quad \text{Verificato } \checkmark$$

$$\hookrightarrow = \emptyset \quad \searrow = \emptyset$$

Soluzione ipotizzata  
(tensioni)

$$\sigma_z = ky$$

$$\boldsymbol{\tau} = \mathbf{0}$$

---

### Condizioni al contorno sul mantello

$$\boldsymbol{\tau} \cdot \mathbf{n} = 0, P \in \Gamma \quad \text{Verificato } \checkmark$$



## 2. Flessione retta $M_x$

Soluzione ipotizzata  
(tensioni)

Equazioni di equivalenza statica

$$N=T_x=T_y=0$$

$$M_x \neq 0, M_y=M_z=0$$

$$N = \int_{\mathcal{A}} \sigma_z dA = \int_{\mathcal{A}} ky dA = k \int_{\mathcal{A}} y dA = k S_x = 0 \quad \text{Verificato } \checkmark$$

$$\sigma_z = ky$$

$$\tau = 0$$

$$T_x = \int_{\mathcal{A}} \tau_{zx} dA = 0 \quad \text{Verificato } \checkmark \quad T_y = \int_{\mathcal{A}} \tau_{zy} dA = 0 \quad \text{Verificato } \checkmark$$

$$M_x = \int_{\mathcal{A}} \sigma_z y dA = \int_{\mathcal{A}} ky^2 dA = k \int_{\mathcal{A}} y^2 dA = k I_x \quad \text{Verificato se } k = \frac{M_x}{I_x} \checkmark$$

$$M_y = \int_{\mathcal{A}} \sigma_z x dA = \int_{\mathcal{A}} kxy dA = k \int_{\mathcal{A}} xy dA = k I_{xy} = 0 \quad \text{Verificato } \checkmark$$

soluzione

$$\sigma_z = \frac{M_x}{I_x} y$$

$$\tau = 0$$

$$M_t = \int_{\mathcal{A}} (\tau_{zy}x - \tau_{zx}y) dA = 0 \quad \text{Verificato } \checkmark$$



## 2. Flessione retta $M_x$

*soluzione*

$$\sigma_z = \frac{M_x}{I_x} y$$
$$\tau = 0$$

### Legge generalizzata di Hooke

$$\varepsilon_x = \varepsilon_y = -\nu \frac{M_x}{EI_x} y \quad \varepsilon_z = \frac{M_x}{EI_x} y \quad \gamma_{zx} = 0 \quad \gamma_{zy} = 0 \quad \text{Verificate } \checkmark$$

### Equazioni implicite di congruenza

$$u = -\nu \frac{M_x}{EI_x} xy + \dots \quad v = -\nu \frac{M_x}{EI_x} [z^2 + \nu(y^2 - x^2)]y + \dots \quad w = \frac{M_x}{EI_x} yz + \dots$$

*Verificate*  $\checkmark$

## 2. Flessione retta $M_x$

### Soluzione in forma chiusa

#### *Spostamenti e deformazioni*

$$u = -\nu \frac{M_x}{EI_x} xy + \dots \quad v = -\frac{M_x}{2EI_x} [z^2 + \nu(y^2 - x^2)]y + \dots \quad w = \frac{M_x}{EI_x} yz + \dots$$

$$\varepsilon_x = \varepsilon_y = -\nu \frac{M_x}{EI_x} y \quad \varepsilon_z = \frac{M_x}{EI_x} y \quad \gamma_{zx} = 0 \quad \gamma_{zy} = 0$$

#### *Rappresentazione grafica*

VEDI  
TRAVE 1D

$$\chi_x = \frac{M_x}{EI_x}$$

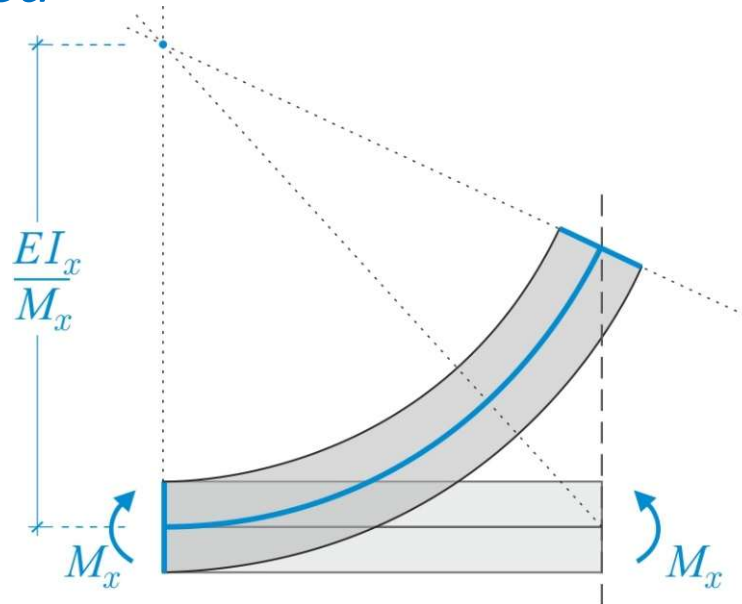

#### *Deformazione della sezione*

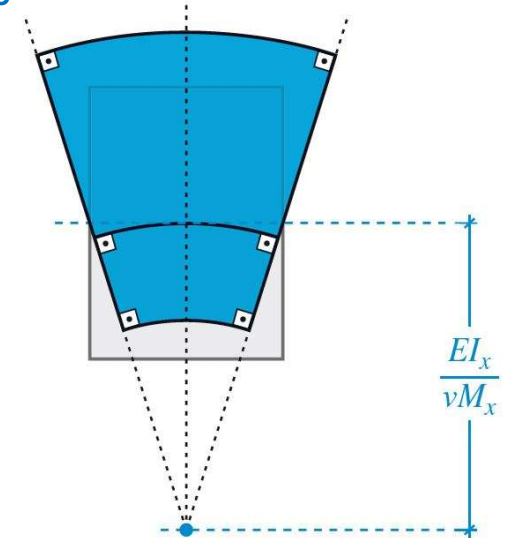

## 2. Flessione retta $M_x$

### Soluzione in forma chiusa

#### Tensioni

$$\boxed{\sigma_z = \frac{M_x}{I_x} y} \quad \tau_{zy} = \tau_{zx} = 0 \quad T(P) = \begin{bmatrix} 0 & 0 & 0 \\ 0 & 0 & 0 \\ 0 & 0 & \frac{M_x}{I_x} y \end{bmatrix}$$

Formula di Navier

#### Rappresentazione grafica

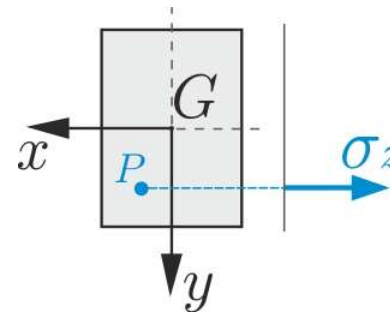
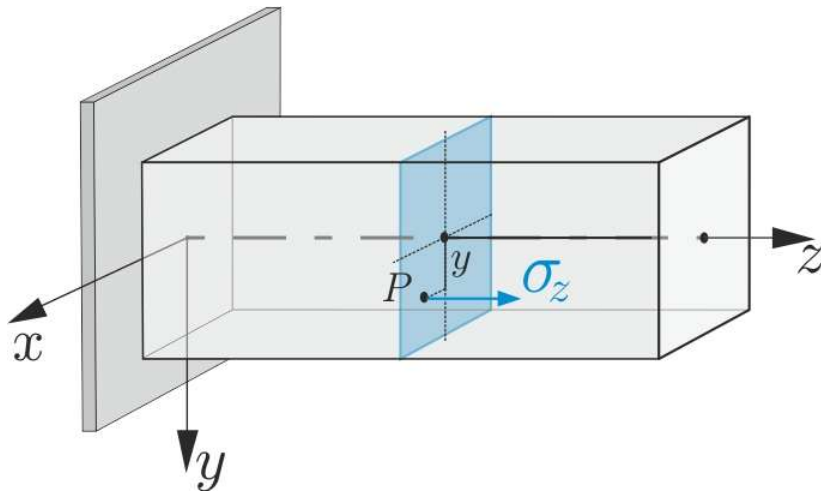

## 2. Flessione retta $M_x$

### Stato tensionale

#### Formula di Navier

$$\sigma_z = \frac{M_x}{I_x} y$$

#### Asse neutro

$$\sigma_z = 0 \Rightarrow y = 0$$

L'asse neutro è  
perpendicolare  
all'asse di  
sollecitazione

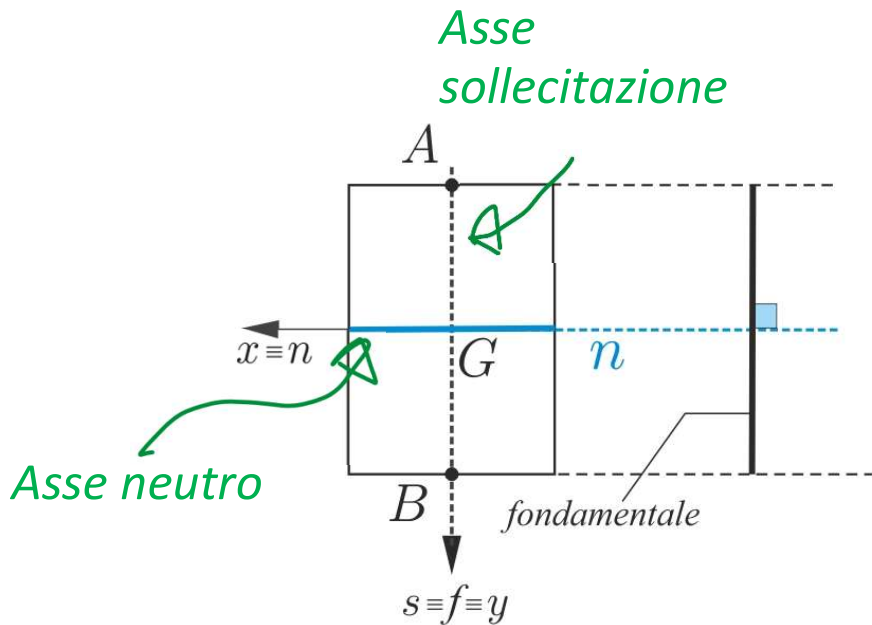

$$A \equiv \left(0, -\frac{h}{2}\right) \quad B \equiv \left(0, +\frac{h}{2}\right)$$

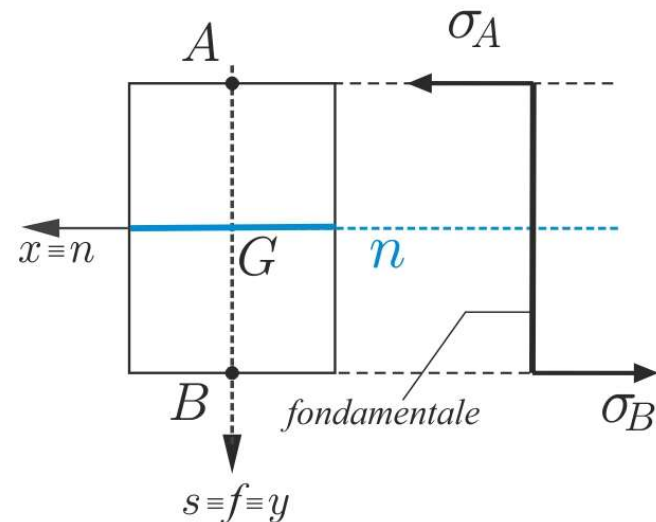

$$\sigma_A = -\frac{M_x}{I_x} \frac{h}{2} \quad \sigma_B = +\frac{M_x}{I_x} \frac{h}{2}$$

## 2. Flessione retta $M_x$

### Posizione del problema

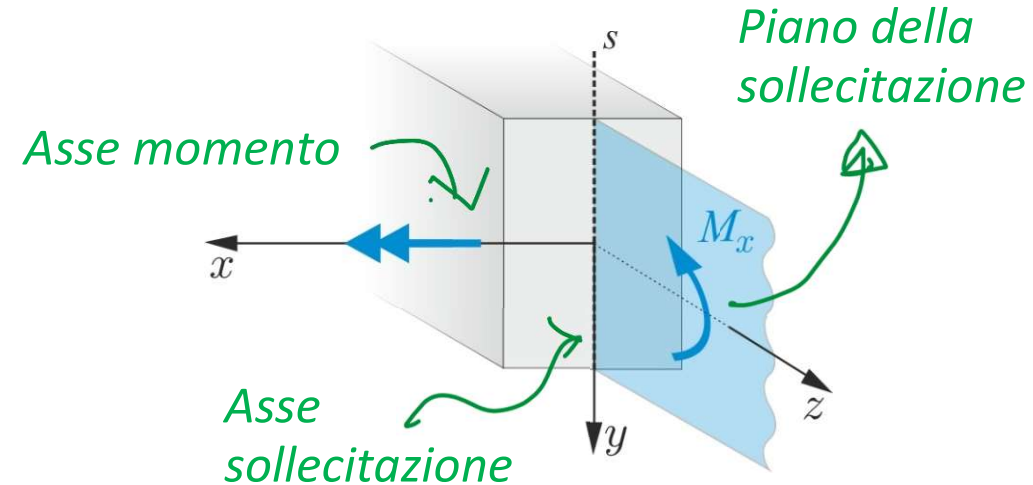
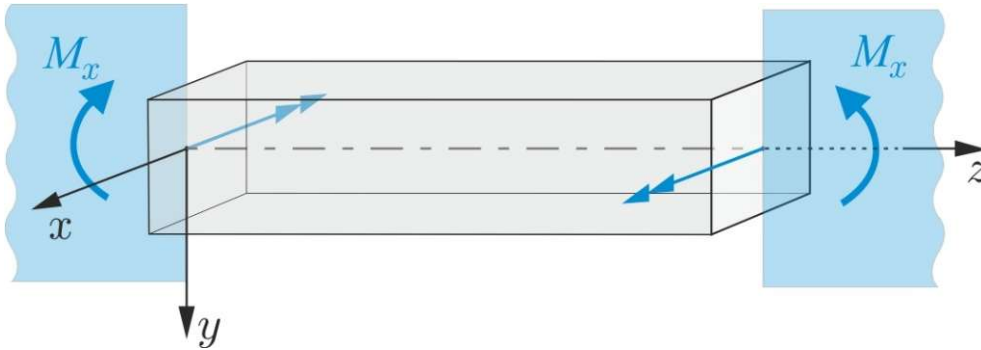

### Soluzione (tensioni)

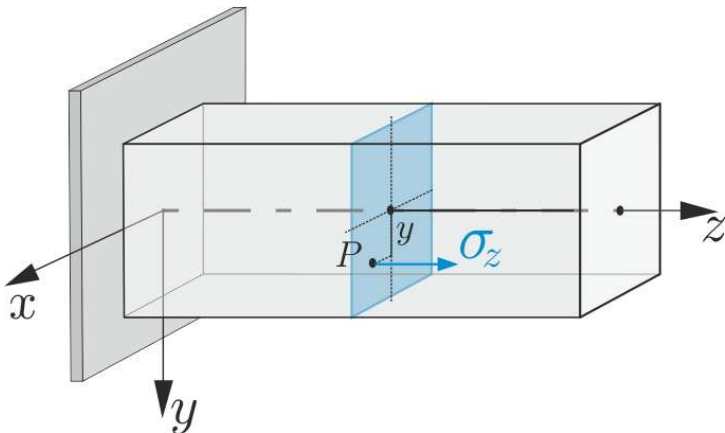

$$\sigma_z(P) = \frac{M_x}{I_x} y$$
$$\tau_{zy}(P) = \tau_{zx}(P) = 0$$

## 2. Flessione retta $M_x$

### Stato tensionale

#### Formula di Navier

$$\sigma_z = \frac{M_x}{I_x} y$$

#### Asse neutro

$$\sigma_z = 0 \Rightarrow y = 0$$

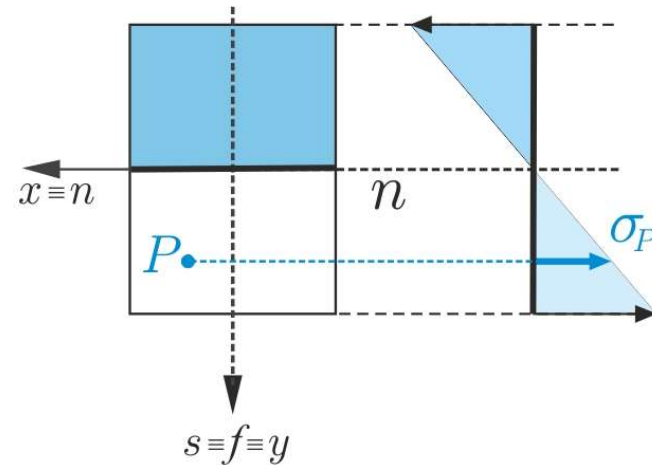
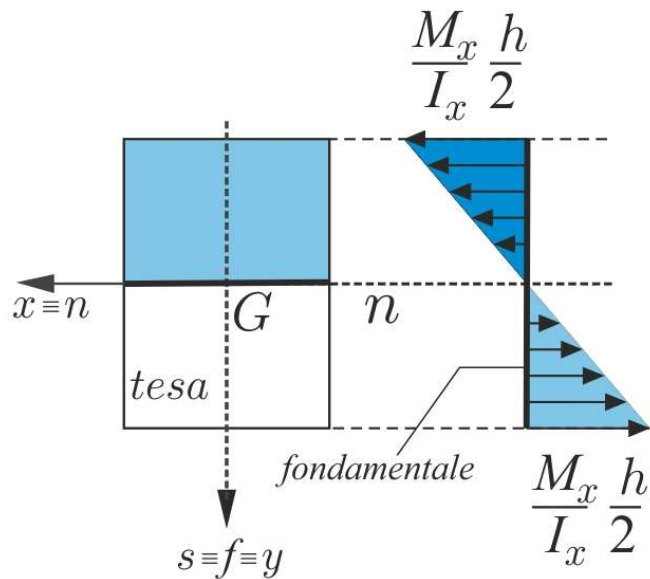

## 2. Flessione retta $M_x$

### Stato tensionale

#### Formula di Navier

$$\sigma_z = \frac{M_x}{I_x} y$$

#### Asse neutro

$$\sigma_z = 0 \Rightarrow y = 0$$

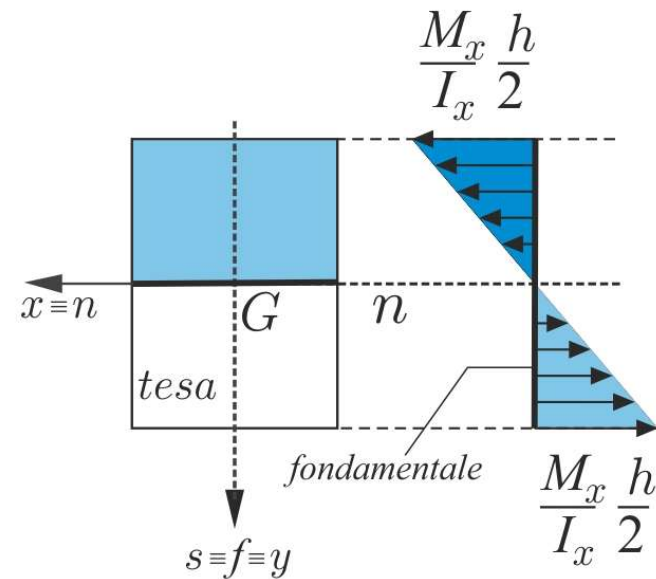
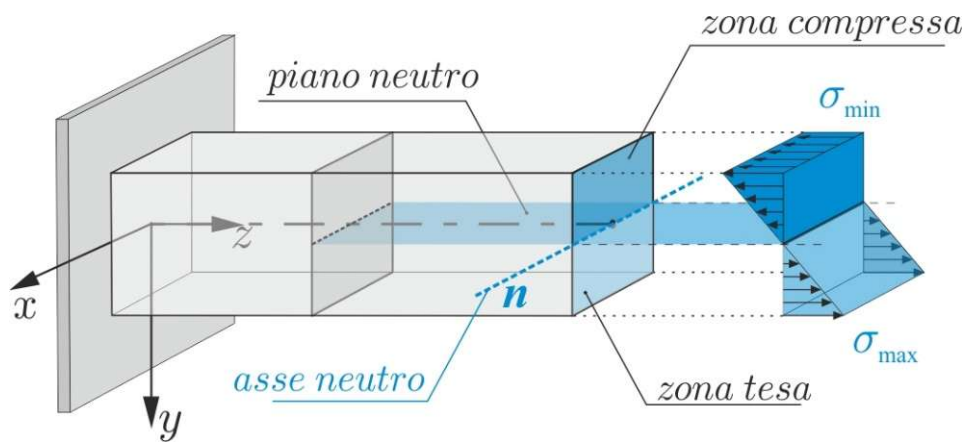

## 2. Flessione retta $M_y$

### Stato tensionale

#### Formula di Navier

$$\sigma_z = -\frac{M_y}{I_y} x$$

#### Asse neutro

$$\sigma_z = 0 \Rightarrow x = 0$$

L'asse neutro è  
perpendicolare  
all'asse di  
sollecitazione

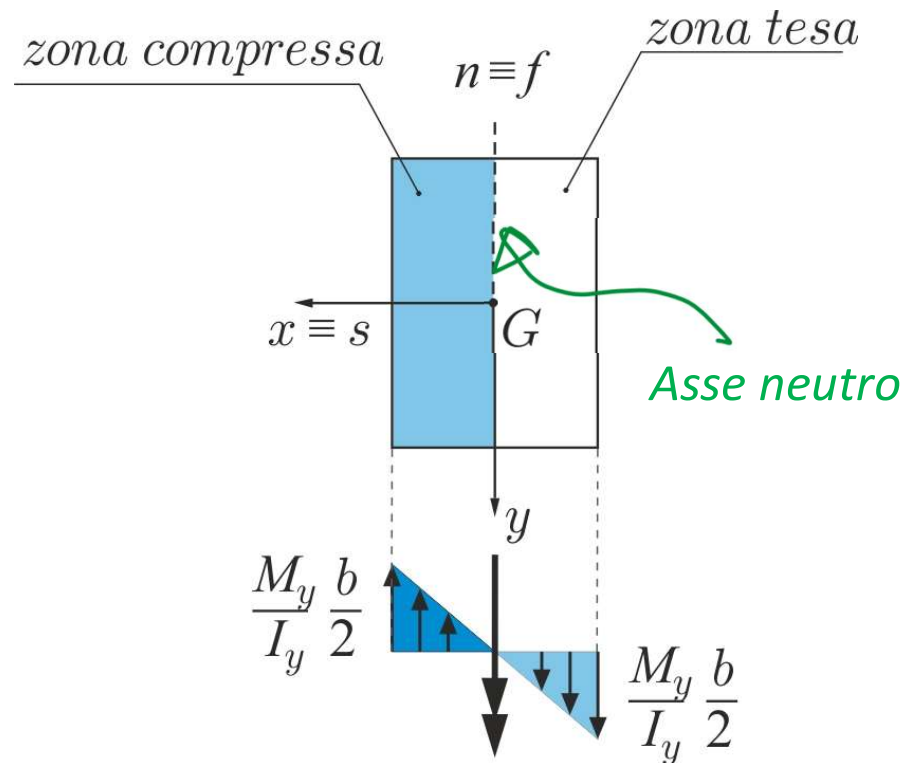
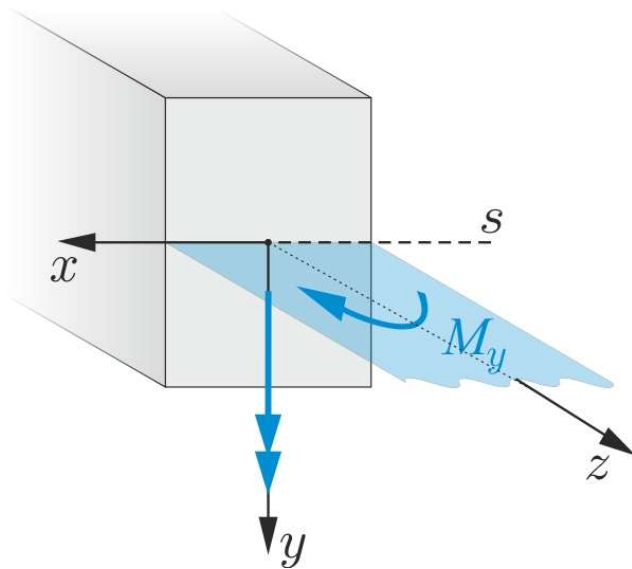

## 2. Flessione retta: Moduli di resistenza della sezione

### Flessione retta $M_x$

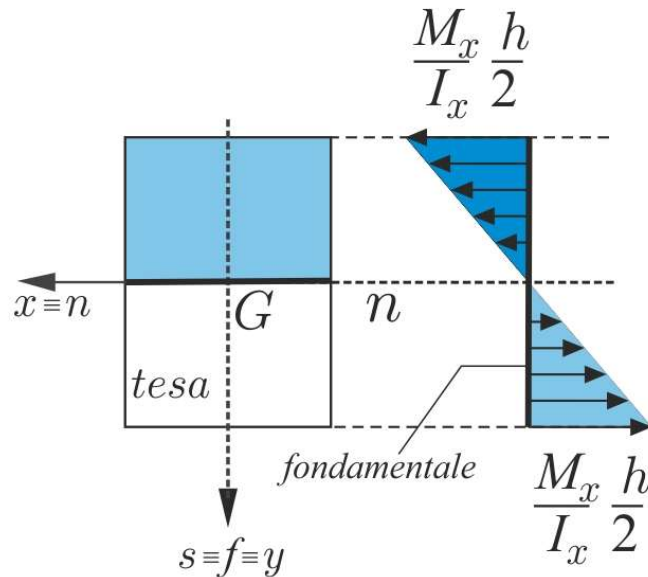

$$\sigma_{max} = \frac{M_x h}{I_x \cdot 2} = \frac{M_x}{\left(\frac{2I_x}{h}\right)} = \frac{M_x}{W_x}$$

$$\sigma_{max} = \frac{M_x}{W_x}$$

$$W_x = \frac{2I_x}{h} \quad \text{modulo di resistenza della sezione nel piano } zy [L^3]$$

### Sezione rettangolare

$$W_x = \frac{1}{6} b h^2$$

## 2. Flessione retta: Moduli di resistenza della sezione

### Flessione retta $M_y$

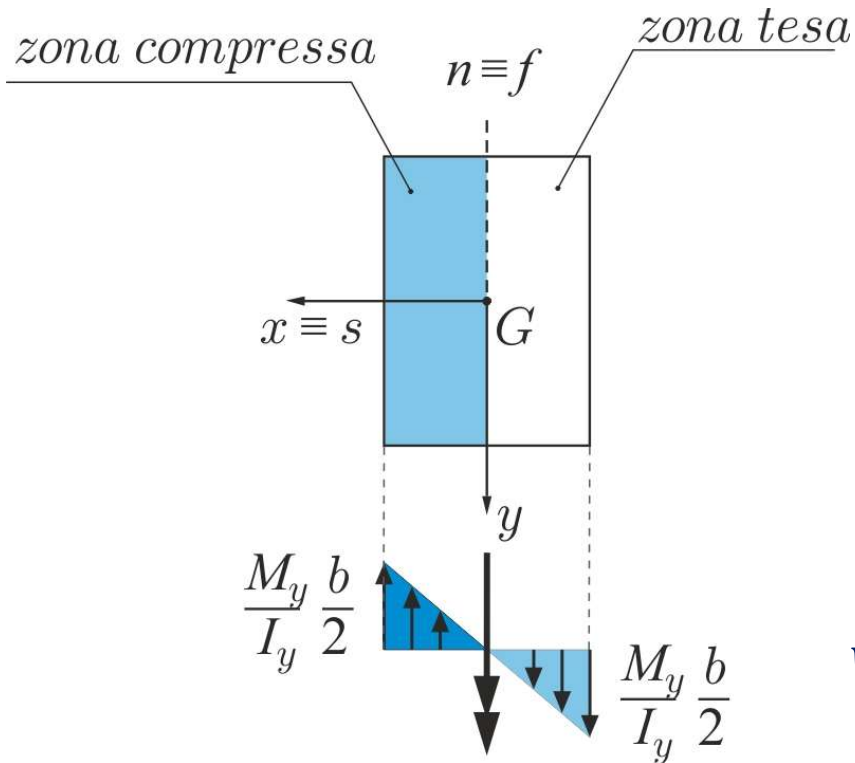

$$\sigma_{max} = \frac{M_y b}{I_y 2} = \frac{M_y}{\left(\frac{2I_y}{b}\right)} = \frac{M_y}{W_y}$$

$$\sigma_{max} = \frac{M_y}{W_y}$$

$$W_y = \frac{2I_y}{b}$$

modulo di resistenza della sezione  
nel piano  $zx$  [ $L^3$ ]

### Sezione rettangolare

$$W_y = \frac{1}{6} hb^2$$