

SISTEMI DI TRAVI ISOSTATICI

ESERCITAZIONI

a cura di P. Casini

Testi consigliati:

1. P. Casini, M. Vasta, *Scienza delle Costruzioni*, CittàStudi (UTET università), 2016.
2. C. Comi, L. Corradi Dell'Acqua: *Introduzione alla meccanica strutturale*, McGraw-Hill, 2007.
3. E. Viola: *Complementi ed esercizi di Scienza delle Costruzioni*, Voll. 1, 2, Pitagora

**1. Sistemi staticamente determinati:
Esercizi svolti**

Esercizio 1.1

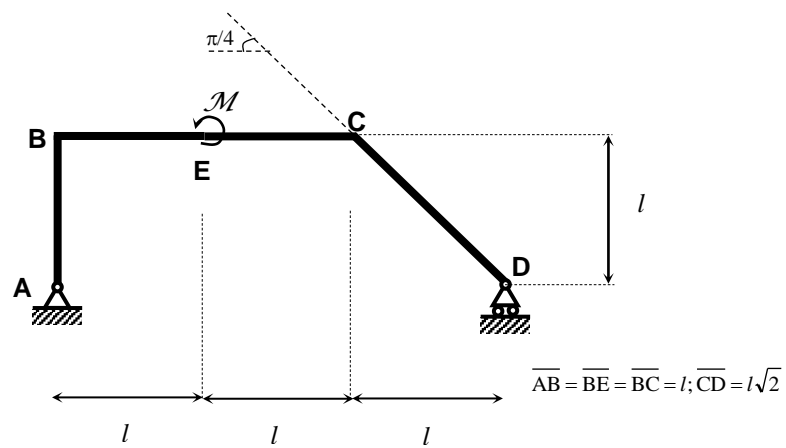

Con riferimento al sistema isostatico mostrato figura si chiede di:

- Calcolare le reazioni vincolari.
- Tracciare i diagrammi delle Caratteristiche della Sollecitazione.

• Calcolo delle reazioni vincolari

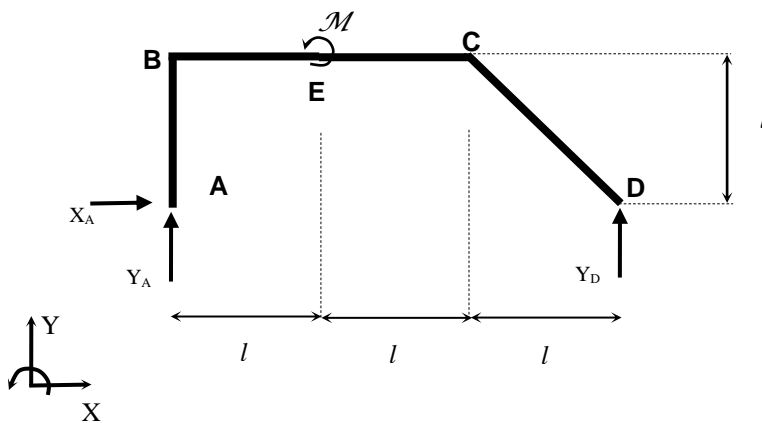

$$\Sigma X = 0$$

$$\Rightarrow X_A = 0$$

$$\begin{aligned} \Sigma Y = 0 & \Rightarrow Y_A + Y_D = 0 \\ \Sigma M_A = 0 & \Rightarrow M + 3lY_D = 0 \Rightarrow Y_D = -M/3l \\ & \Rightarrow Y_A = M/3l \end{aligned}$$

• Riepilogo delle reazioni vincolari

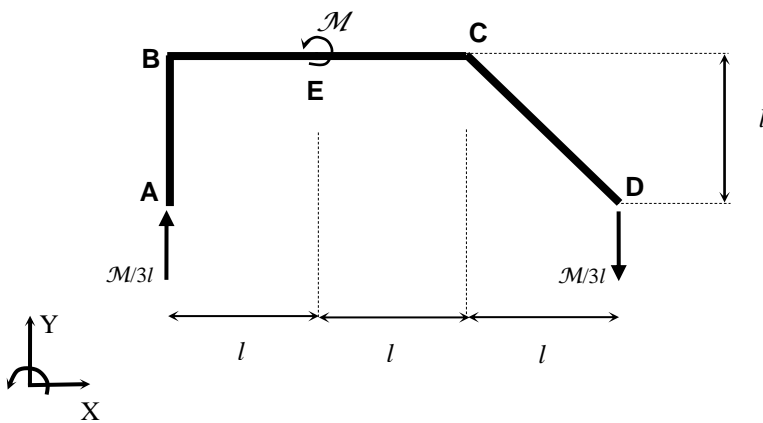

• Verifiche

$$\begin{aligned} \Sigma Y = 0 & \Rightarrow M/3l - M/3l = 0 \quad \checkmark \\ \Sigma M_E = 0 & \Rightarrow M - (M/3l)l - (M/3l)(2l) = 0 \quad \checkmark \end{aligned}$$

• Caratteristiche della Sollecitazione)

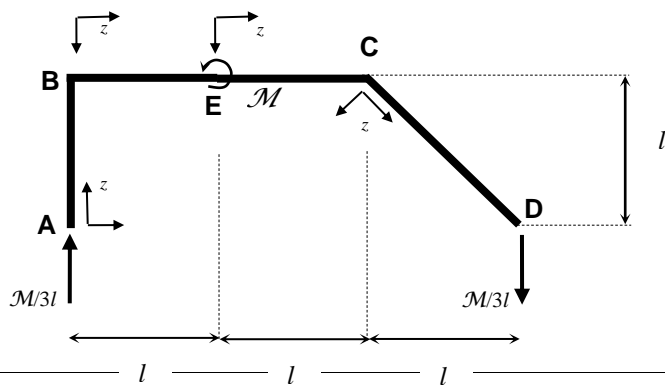

• Tratto AB

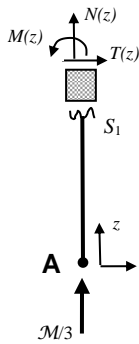

$$\begin{aligned} N(z) + \mathcal{M}/3l &= 0 \\ T(z) &= 0 \\ \Sigma M_{S1} &= 0 \end{aligned}$$

$$\begin{aligned} N(z) &= -\mathcal{M}/3l \\ T(z) &= 0 \\ M(z) &= 0 \end{aligned}$$

- $z = 0 \Rightarrow S_1 \equiv A$

$$\begin{aligned} N(0) &= N_A = -\mathcal{M}/3l \\ T(0) &= T_A = 0 \\ M(0) &= M_A = 0 \end{aligned}$$

- $z = l \Rightarrow S_1 \equiv B^-$

$$\begin{aligned} N(l) &= N_{B^-} = -\mathcal{M}/3l \\ T(l) &= T_{B^-} = 0 \\ M(l) &= M_{B^-} = 0 \end{aligned}$$

• **Nodo B**

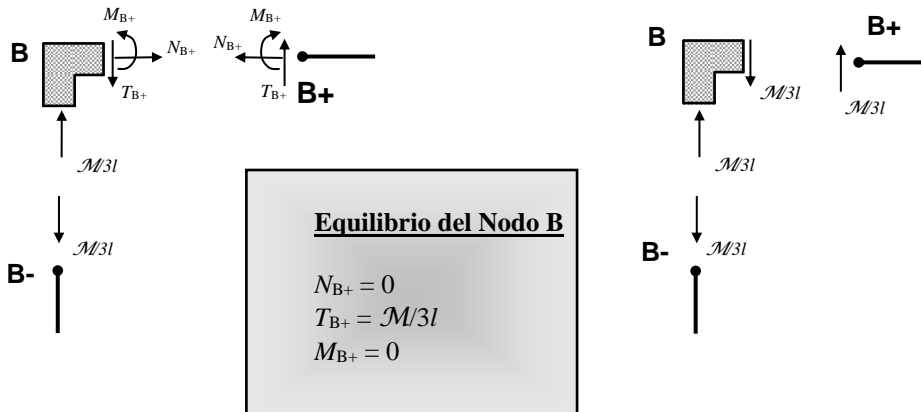

• **Tratto BE**

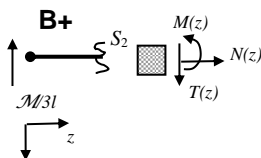

$$\begin{aligned} N(z) &= 0 \\ T(z) - \mathcal{M}/3l &= 0 \\ \Sigma M_{S1} &= 0 \end{aligned}$$

$$\begin{aligned} N(z) &= 0 \\ T(z) &= \mathcal{M}/3l \\ M(z) &= (\mathcal{M}/3l)z \end{aligned}$$

- $z = 0 \Rightarrow S_2 \equiv B^+ \quad N(0) = N_{B^+} = 0$

$$T(0) = T_{B+} = \mathcal{M}/3l$$

$$M(0) = M_{B+} = 0$$

- $z = l \Rightarrow S_2 \equiv E-$

$$N(l) = N_{E-} = 0$$

$$T(l) = T_{E-} = \mathcal{M}/3l$$

$$M(l) = M_{E-} = \mathcal{M}/3$$

- **Nodo E**

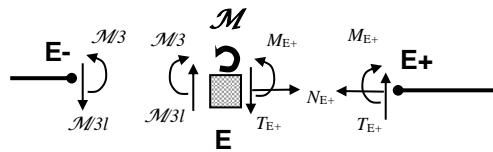

Equilibrio del Nodo E

$$N_{E+} = 0$$

$$T_{E+} = \mathcal{M}/3l$$

$$M_{E+} = -(2/3)\mathcal{M}$$

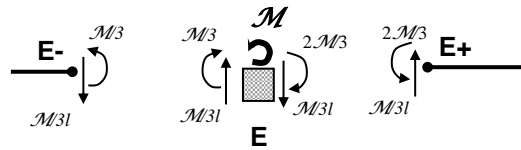

- **Tratto EC**

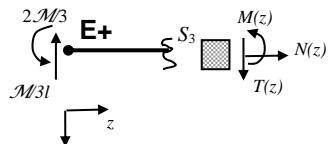

$$N(z) = 0$$

$$T(z) - \mathcal{M}/3l = 0$$

$$\Sigma M_{S3} = 0$$

$$N(z) = 0$$

$$T(z) = \mathcal{M}/3l$$

$$M(z) = -(2/3)\mathcal{M} + (\mathcal{M}/3l)z$$

- $z = 0 \Rightarrow S_3 \equiv E+$

$$N(0) = N_{E+} = 0$$

$$T(0) = T_{E+} = \mathcal{M}/3l$$

$$M(0) = M_{E+} = -(2/3)\mathcal{M}$$

- $z = l \Rightarrow S_3 \equiv C-$

$$N(l) = N_{C-} = 0$$

$$T(l) = T_{C-} = \mathcal{M}/3l$$

$$M(l) = M_{C-} = -\mathcal{M}/3$$

• **Nodo C**

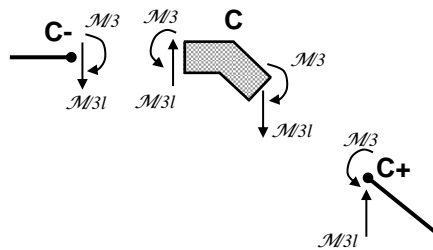

• **Tratto CD**

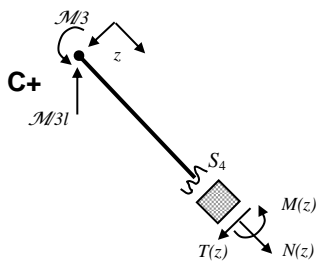

$$N(z) - \frac{\mathcal{M}}{3l} \frac{\sqrt{2}}{2} = 0 \quad N(z) = \frac{\mathcal{M}}{6l} \sqrt{2}$$

$$T(z) - \frac{\mathcal{M}}{3l} \frac{\sqrt{2}}{2} = 0 \quad T(z) = \frac{\mathcal{M}}{6l} \sqrt{2}$$

$$\Sigma M_{S4} = 0 \quad M(z) = -\frac{\mathcal{M}}{3} + \frac{\mathcal{M}\sqrt{2}}{6l} z$$

- $z = 0 \Rightarrow S_4 \equiv C+$

$$N(0) = N_{C+} = \frac{\mathcal{M}}{6l} \sqrt{2}$$

$$T(0) = T_{C+} = \frac{\mathcal{M}}{6l} \sqrt{2}$$

$$M(0) = M_{C+} = -\mathcal{M}/3$$

- $z = l\sqrt{2} \Rightarrow S_4 \equiv D$

$$N(l\sqrt{2}) = N_D = \frac{\mathcal{M}}{6l} \sqrt{2}$$

$$T(l\sqrt{2}) = T_D = \frac{\mathcal{M}}{6l} \sqrt{2}$$

$$M(l\sqrt{2}) = M_D = 0$$

• Diagrammi delle Caratteristiche della Sollecitazione

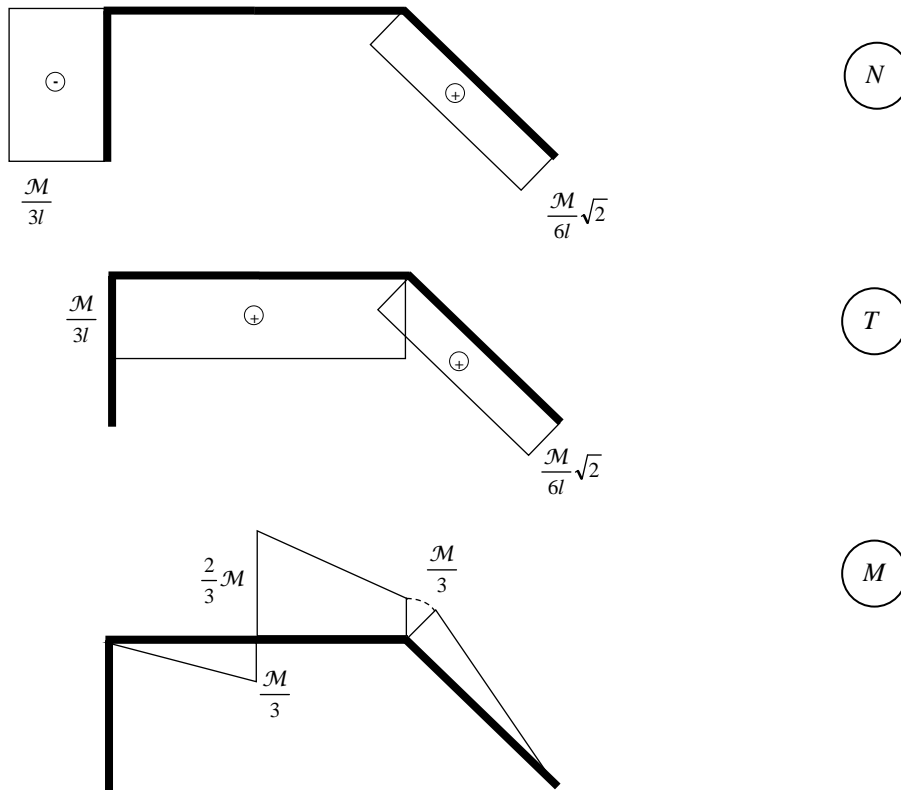

Esercizio 1.2

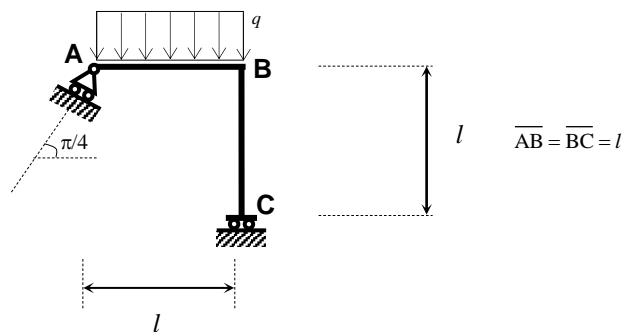

• Calcolo delle reazioni vincolari

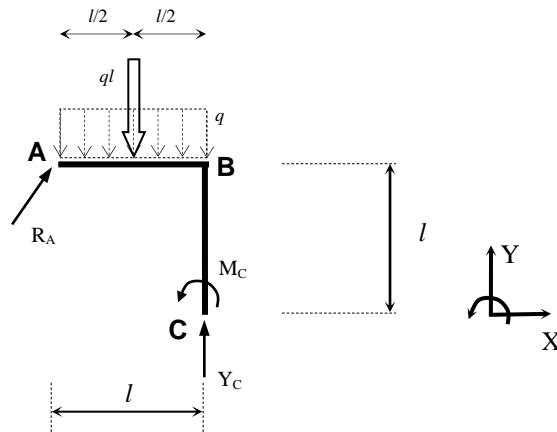

$$\begin{aligned} \Sigma X = 0 & \Rightarrow R_A \frac{\sqrt{2}}{2} = 0 & \Rightarrow R_A = 0 \\ \Sigma Y = 0 & \Rightarrow Y_C - ql = 0 & \Rightarrow Y_C = ql \\ \Sigma M_C = 0 & \Rightarrow (ql)(l/2) + M_C = 0 & \Rightarrow M_C = -\frac{ql^2}{2} \end{aligned}$$

• Riepilogo delle reazioni vincolari

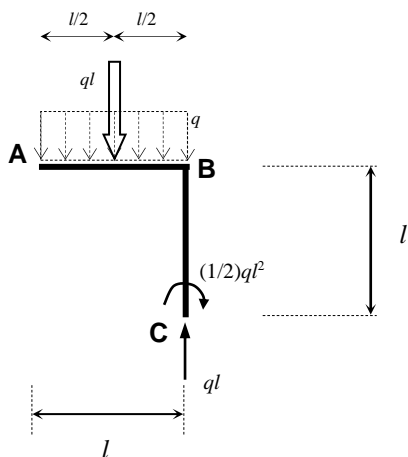

• Verifiche

$$\Sigma Y = -ql + ql = 0 \quad \checkmark$$

$$\Sigma M_A = -ql \frac{l}{2} + ql^2 - \frac{ql^2}{2} = 0 \quad \checkmark$$

• Caratteristiche della Sollecitazione

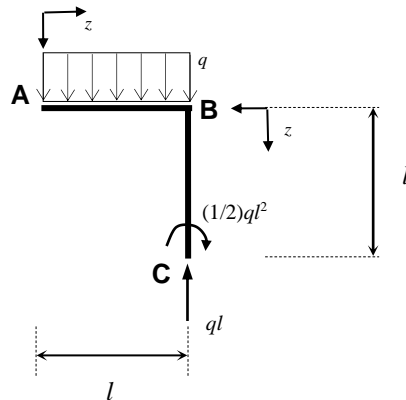

• Tratto AB

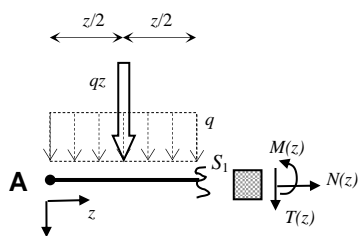

$$N(z) = 0$$

$$T(z) = -qz$$

$$M(z) = -(1/2)qz^2$$

- $z = 0 \Rightarrow S_1 \equiv A$

$$N(0) = N_A = 0$$

$$T(0) = T_A = 0$$

$$M(0) = M_A = 0$$
- $z = l \Rightarrow S_1 \equiv B^-$

$$N(l) = N_{B^-} = 0$$

$$T(l) = T_{B^-} = -ql$$

$$M(l) = M_{B^-} = -(1/2)ql^2$$

• Nodo B

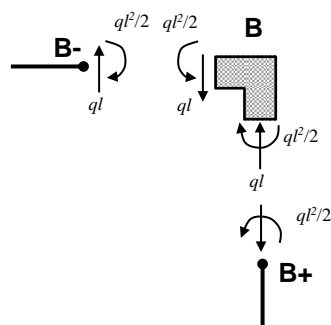

• **Tratto BC**

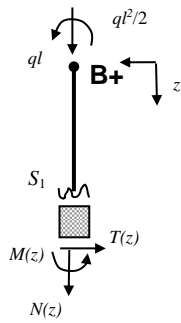

$$N(z) = -ql$$

$$T(z) = 0$$

$$M(z) = - (1/2)ql^2$$

• **Diagrammi delle Caratteristiche della Sollecitazione**

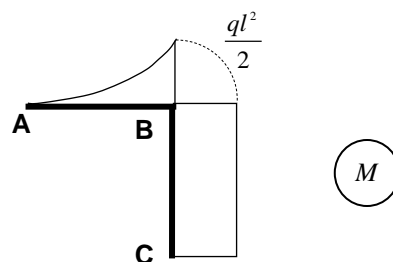
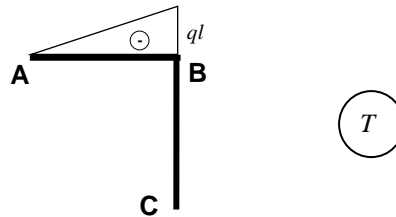
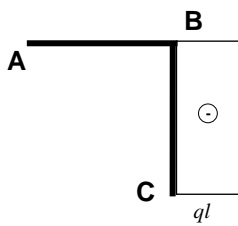

Esercizio 1.3

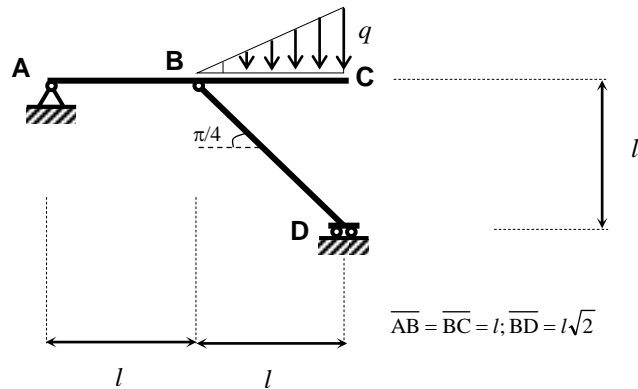

• **Calcolo delle reazioni vincolari**

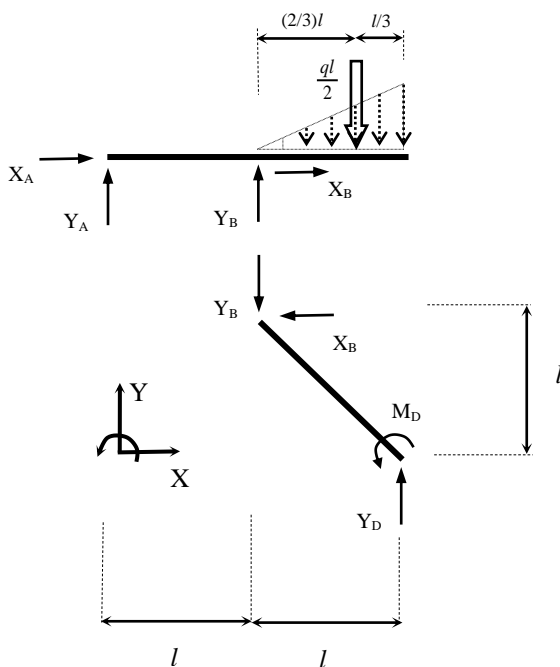

• **Equilibrio asta BD**

$$\begin{aligned} -X_B &= 0 \\ Y_D - Y_B &= 0 \\ M_D + X_B l + Y_B l &= 0 \end{aligned}$$

$$\begin{aligned} X_B &= 0 \\ Y_B &= Y_D \\ M_D &= -Y_B l \end{aligned}$$

• **Equilibrio asta ABC**

$$\begin{aligned} X_A &= 0 \\ Y_A + Y_B - ql/2 &= 0 \\ Y_B l - (ql/2)[l + (2/3)l] &= 0 \end{aligned}$$

$$\begin{aligned} X_A &= 0 & X_B &= 0 \\ Y_B &= (5/6)ql & Y_A &= -ql/3 \\ Y_D &= (5/6)ql & & \\ M_D &= -(5/6)ql^2 & & \end{aligned}$$

• Riepilogo delle reazioni vincolari

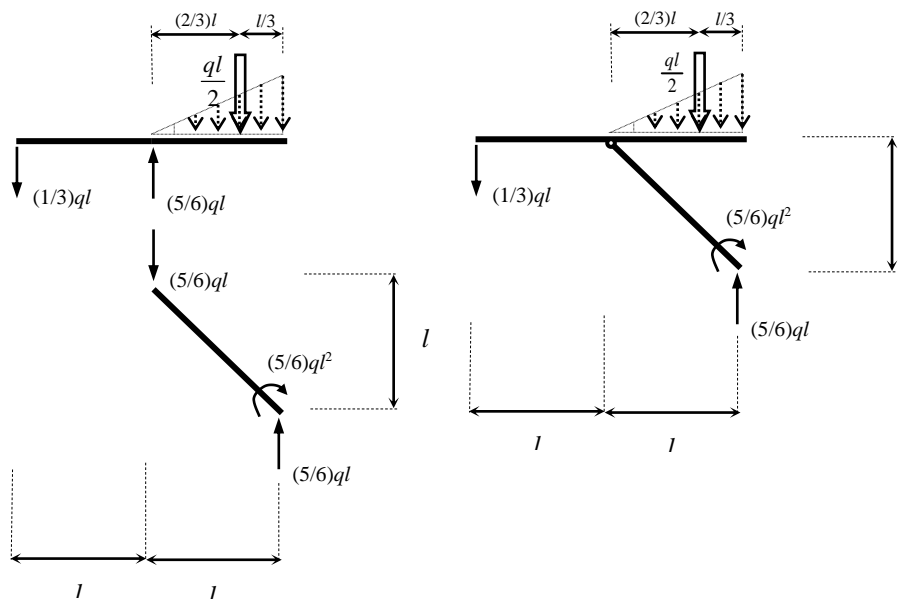

• Verifiche

$$\Sigma Y = 0 \quad \Rightarrow \quad -\frac{ql}{3} + \frac{5ql}{6} - \frac{ql}{2} = 0 \quad \checkmark$$

$$\Sigma M_B = 0 \quad \Rightarrow \quad \frac{ql}{3}l + \frac{5ql}{6}l - \frac{5}{6}ql^2 - \frac{ql}{2} \frac{2}{3}l = 0 \quad \checkmark$$

• Caratteristiche della Sollecitazione

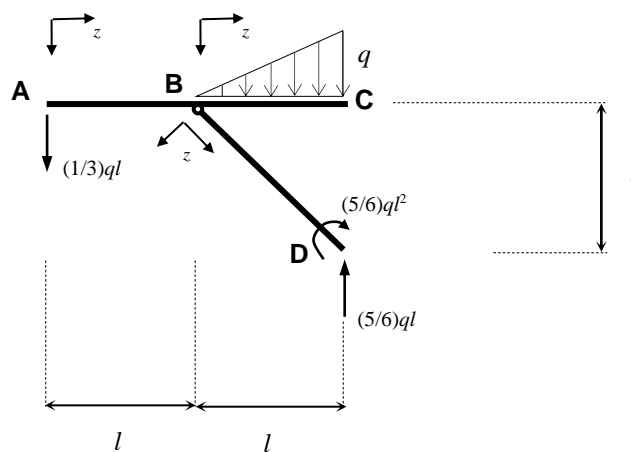

• **Tratto AB**

$$N(z) = 0$$

$$T(z) = -(1/3)ql$$

$$M(z) = -(1/3)ql z$$

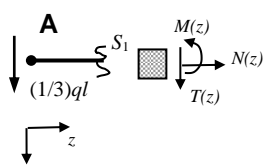

- $z = 0 \Rightarrow S_1 \equiv A$
- $z = l \Rightarrow S_1 \equiv B$

$$N(0) = N_A = 0$$

$$T(0) = T_A = -(1/3)ql$$

$$M(0) = M_A = 0$$

$$N(l) = N_B = 0$$

$$T(l) = T_B = (1/3)ql$$

$$M(l) = M_B = -(1/3)ql^2$$

• **Nodo B**

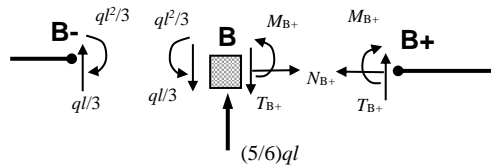

Equilibrio del Nodo B

$$N_{B+} = 0$$

$$T_{B+} = ql/2$$

$$M_{B+} = -ql^2/3$$

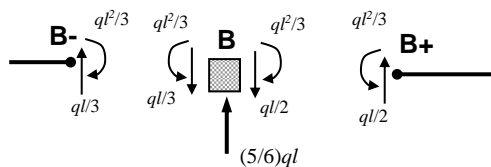

• **Tratto BC**

La legge di variazione del carico distribuito nel sistema di riferimento locale è $q(z) = \frac{q}{l}z$. Le equazioni di Equilibrio del tratto B+S₂ comportano (vedi Fig.):

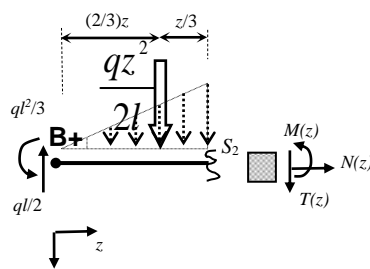

$$N(z) = 0$$

$$T(z) = \frac{ql}{2} - \frac{qz^2}{2l}$$

$$M(z) = -\frac{ql^2}{3} + \frac{ql}{2}z - \frac{qz^3}{6}$$

- $z = 0 \Rightarrow S_2 \equiv B+$

$$N(0) = N_{B+} = 0$$

$$T(0) = T_{B+} = (1/2)ql$$

$$M(0) = M_{B+} = -(1/3)ql^2$$
- $z = l \Rightarrow S_2 \equiv C$

$$N(l) = N_C = 0$$

$$T(l) = T_C = 0$$

$$M(l) = M_C = 0$$

• **Tratto BD**

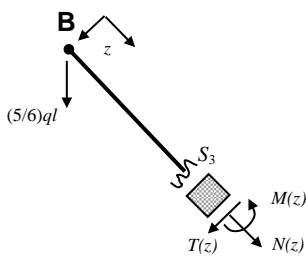

$$N(z) + \frac{5}{6}ql \frac{\sqrt{2}}{2} = 0$$

$$N(z) = -\frac{5}{12}ql\sqrt{2}$$

$$T(z) + \frac{5}{6}ql \frac{\sqrt{2}}{2} = 0$$

$$T(z) = -\frac{5}{12}ql\sqrt{2}$$

$$\Sigma M_{S3} = 0$$

$$M(z) = -\frac{5}{12}ql\sqrt{2}z$$

- $z = 0 \Rightarrow S_3 \equiv B$

$$N(0) = N_B = -\frac{5}{12}ql\sqrt{2}$$

$$T(0) = T_B = -\frac{5}{12}ql\sqrt{2}$$

$$M(0) = M_B = 0$$

- $z = l\sqrt{2} \Rightarrow S_3 \equiv D$

$$N(l\sqrt{2}) = N_D = -\frac{5}{12}ql\sqrt{2}$$

$$T(l\sqrt{2}) = T_D = -\frac{5}{12}ql\sqrt{2}$$

$$M(l\sqrt{2}) = M_D = -\frac{5}{6}ql^2$$

• Diagrammi delle Caratteristiche della Sollecitazione

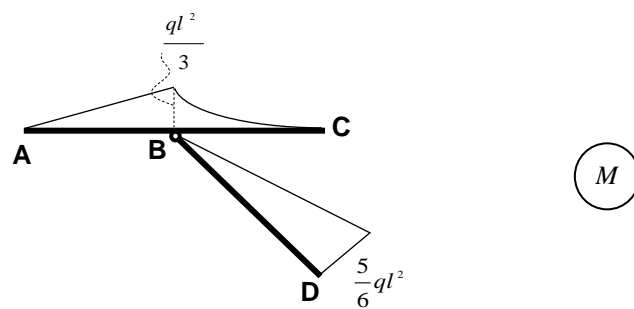
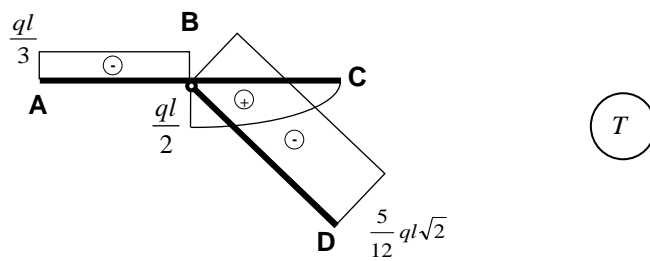
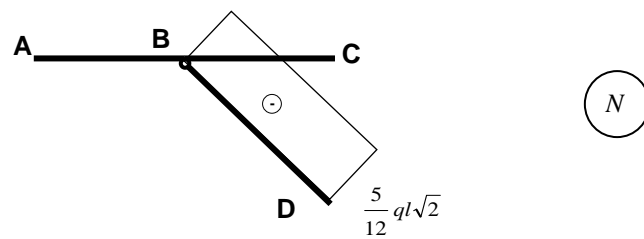

Esercizio 1.4

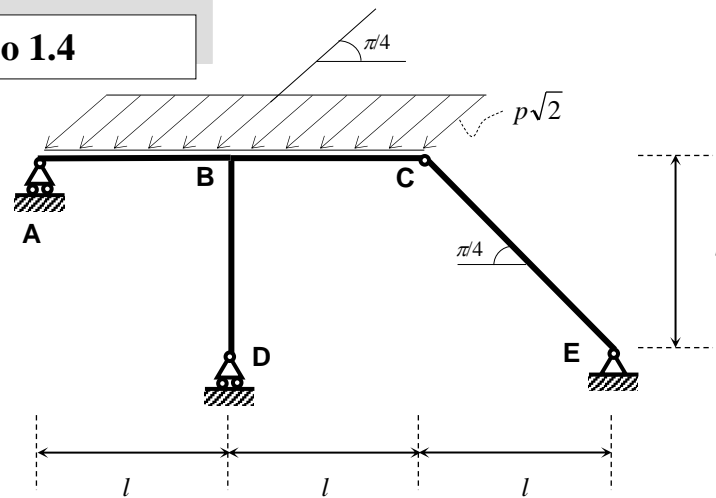

• **Calcolo delle reazioni vincolari**

Il sistema assegnato è staticamente determinato (la dimostrazione si lascia per esercizio).

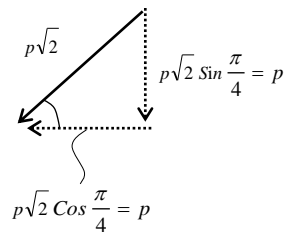

Come prima cosa conviene scomporre il carico distribuito in una componente perpendicolare e in una componente parallela alla direzione AC. Si osserva poi che l'asta EC è sottoposta unicamente a forza normale; pertanto le reazioni vincolari delle cerniere C ed E devono essere parallele alla direzione EC.

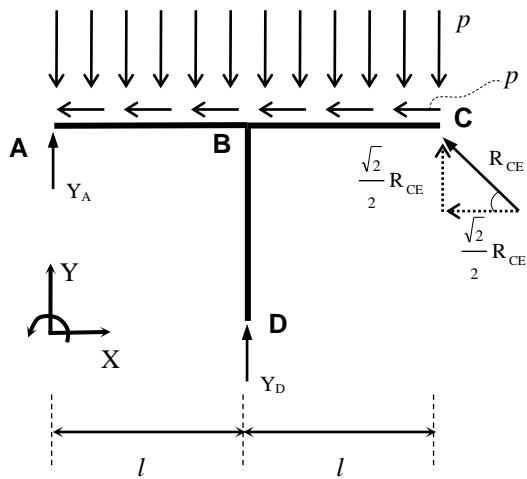

• **Equilibrio corpo ABCD**

$$-\int_0^{2l} p dx - \frac{\sqrt{2}}{2} R_{CE} = 0$$

$$-\int_0^{2l} p dx + \frac{\sqrt{2}}{2} R_{CE} + Y_A + Y_D = 0$$

$$-\int_0^{2l} p x dx + \frac{\sqrt{2}}{2} R_{CE} 2l + Y_D l = 0$$

$$R_{CE} = -pl 2\sqrt{2}$$

$$Y_D = 6pl$$

$$Y_A = -2pl$$

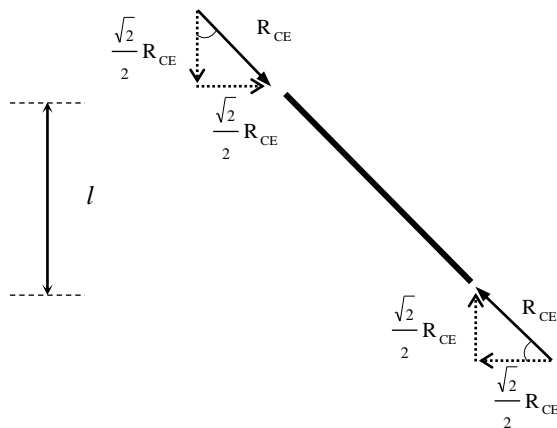

• Riepilogo delle reazioni vincolari

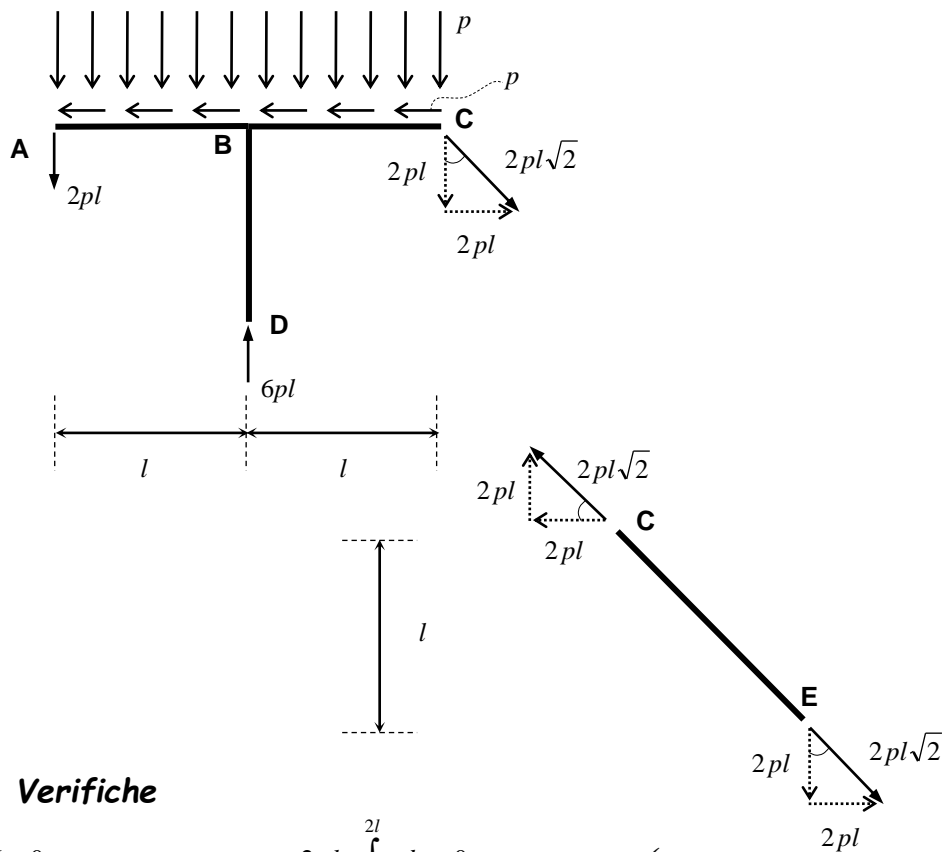

• Verifiche

$$\begin{aligned} \Sigma X = 0 & \Rightarrow -2pl + \int_0^{2l} p dx = 0 \quad \checkmark \\ \Sigma Y = 0 & \Rightarrow -2pl + 6pl - 2pl - \int_0^{2l} p dx = 0 \quad \checkmark \\ \Sigma M_D = 0 & \Rightarrow 2pl^2 + 2pl^2 - 2pl^2 - \int_0^{2l} pl dx = 0 \quad \checkmark \end{aligned}$$

• Caratteristiche della Sollecitazione

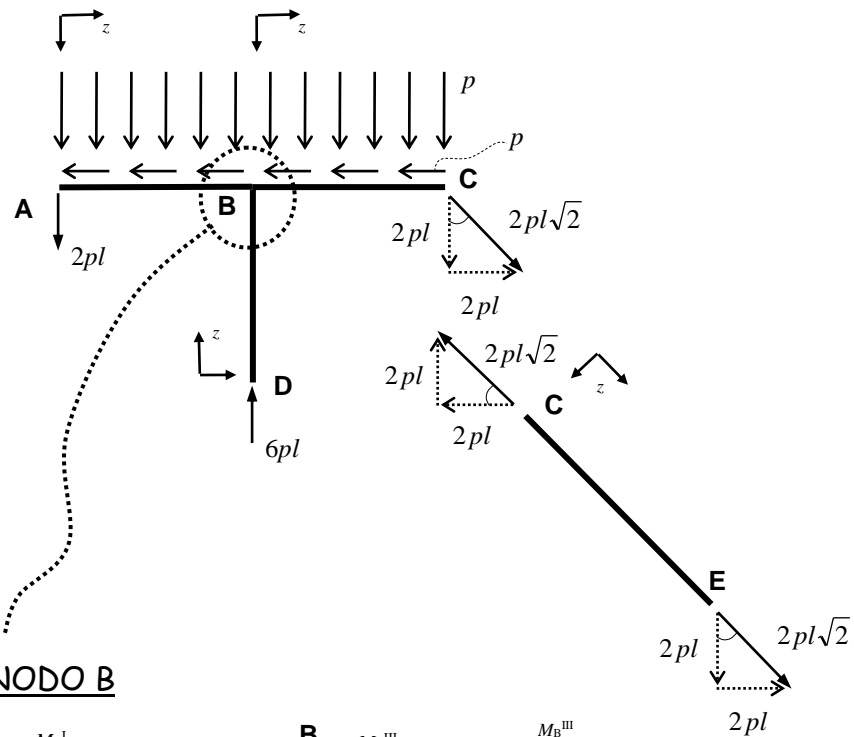

• NODO B

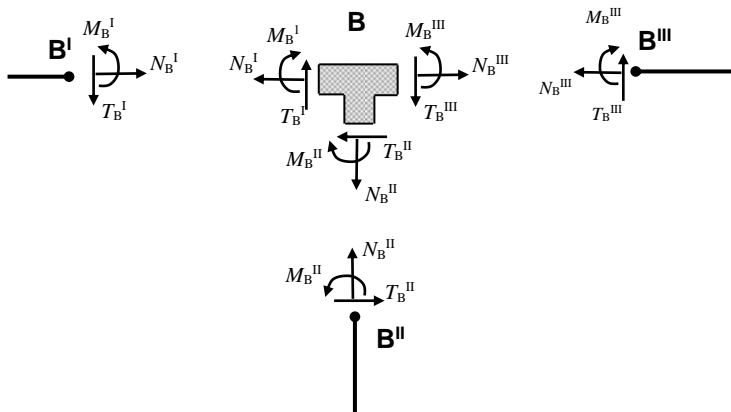

• **Tratto AB**

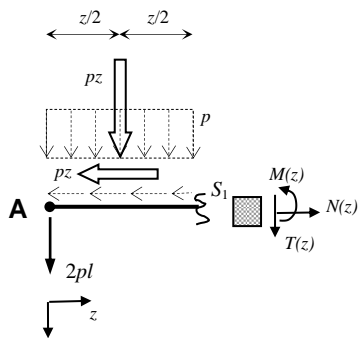

$$N(z) = pz$$

$$T(z) = -2pl - pz$$

$$M(z) = -2plz - (1/2)pz^2$$

- $z = 0 \Rightarrow S_1 \equiv A$

$$N(0) = N_A = 0$$

$$T(0) = T_A = -2pl$$

$$M(0) = M_A = 0$$
- $z = l \Rightarrow S_1 \equiv B^I$

$$N(l) = N_B^I = pl$$

$$T(l) = T_B^I = -3pl$$

$$M(l) = M_B^I = -(5/2)pl^2$$

• **Tratto DB**

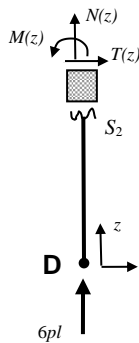

$$N(z) = -6pl$$

$$T(z) = 0$$

$$M(z) = 0$$

- $z = 0 \Rightarrow S_2 \equiv D$

$$N(0) = N_D = -6pl$$

$$T(0) = T_D = 0$$

$$M(0) = M_D = 0$$
- $z = l \Rightarrow S_2 \equiv B^{II}$

$$N(l) = N_B^{II} = -6pl$$

$$T(l) = T_B^{II} = 0$$

$$M(l) = M_B^{II} = 0$$

• **Nodo B**

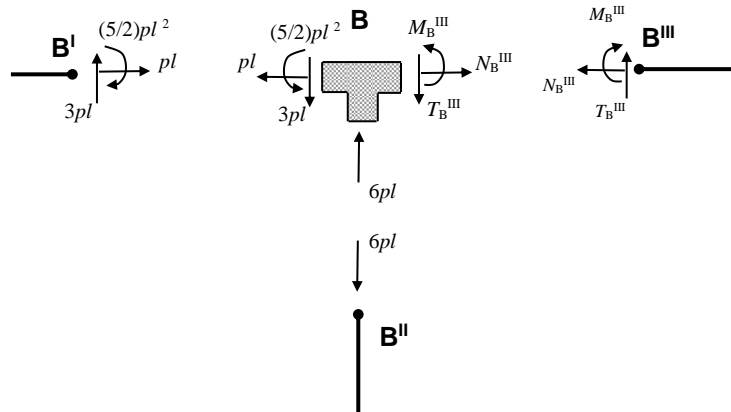

Equilibrio del Nodo B

$$\begin{aligned}
 N_B^{III} &= pl \\
 T_B^{III} &= 3pl \\
 M_B^{III} &= -(5/2) pl^2
 \end{aligned}$$

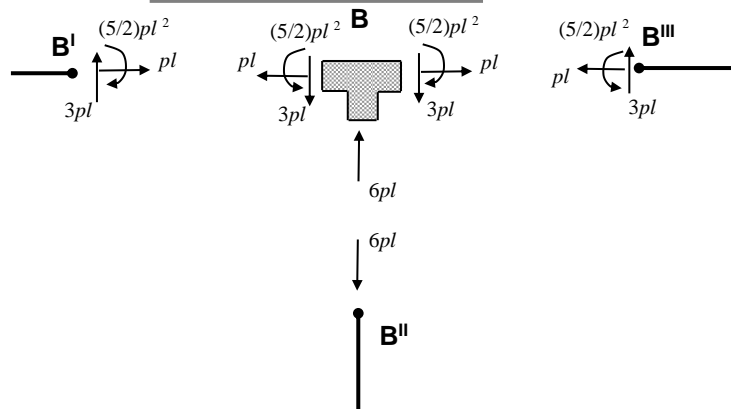

• **Tratto BC**

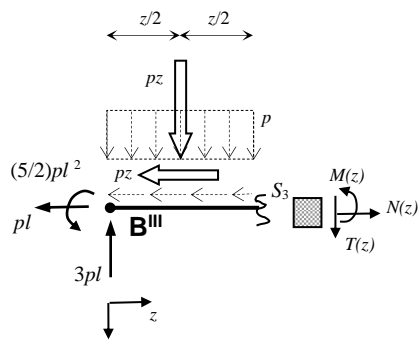

$$N(z) = pl + pz$$

$$T(z) = 3pl - pz$$

$$M(z) = -(5/2)pl^2 + 3plz - (1/2)pz^2$$

- $z = 0 \Rightarrow S_3 \equiv B^{\text{III}}$

$$N(0) = N_{B^{\text{III}}} = -pl$$

$$T(0) = T_{B^{\text{III}}} = 3pl$$

$$M(0) = M_{B^{\text{III}}} = -(5/2)pl^2$$
- $z = l \Rightarrow S_3 \equiv C$

$$N(l) = N_C = 2pl$$

$$T(l) = T_C = 2pl$$

$$M(l) = M_C = 0$$

• **Tratto CE**

$$N(z) = 2pl\sqrt{2}$$

$$T(z) = 0$$

$$M(z) = 0$$

- Diagrammi delle caratteristiche della sollecitazione

